

# PRODUCT INFORMATION PACKET

Model No: 326TTFCD6028

Catalog No: GT1237A

50 HP General Purpose Motor, 3 phase, 1800 RPM, 230/460 V, 326TC Frame, TEFC  
Three Phase TEFC Motors



### Nameplate Specifications

Output HP	<b>50 Hp</b>	Output KW	<b>37.0 kW</b>
Frequency	<b>60 Hz</b>	Voltage	<b>230/460 V</b>
Current	<b>117.0/58.5 A</b>	Speed	<b>1780 rpm</b>
Service Factor	<b>1.15</b>	Phase	<b>3</b>
Efficiency	<b>94.5 %</b>	Power Factor	<b>85</b>
Duty	<b>Continuous</b>	Insulation Class	<b>F</b>
Design Code	<b>B</b>	KVA Code	<b>G</b>
Frame	<b>326TC</b>	Enclosure	<b>Totally Enclosed Fan Cooled</b>
Thermal Protection	<b>No</b>	Ambient Temperature	<b>40 °C</b>
Drive End Bearing Size	<b>6312</b>	Opp Drive End Bearing Size	<b>6212</b>
UL	<b>Listed</b>	CSA	<b>Y</b>
CE	<b>Y</b>	IP Code	<b>55</b>
Hazardous Location	<b>DIVISION 2 T2B</b>		

### Technical Specifications

Electrical Type	<b>Squirrel Cage Inverter Rated</b>	Starting Method	<b>Line Or Inverter</b>
Poles	<b>4</b>	Rotation	<b>Selective Clockwise</b>
Resistance Main	<b>.127 Ohms</b>	Mounting	<b>Rigid Base</b>
Motor Orientation	<b>Horizontal</b>	Drive End Bearing	<b>Ball</b>
Opp Drive End Bearing	<b>Ball</b>	Frame Material	<b>Cast Iron</b>
Shaft Type	<b>T</b>	Overall Length	<b>31.19 in</b>
Frame Length	<b>14.56 in</b>	Shaft Diameter	<b>2.125 in</b>
Shaft Extension	<b>5.25 in</b>	Assembly/Box Mounting	<b>F1/F2 CAPABLE</b>
Connection Drawing	<b>EE7308AA</b>	Outline Drawing	<b>SS312784</b>



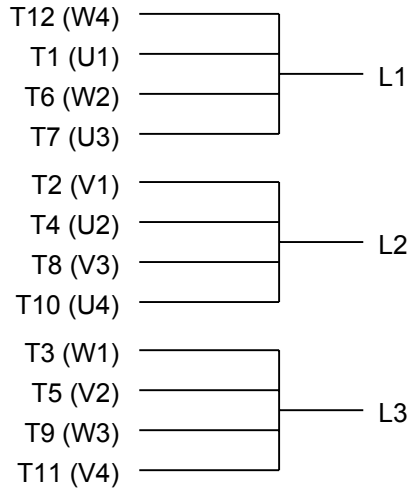

### LOW VOLTAGE

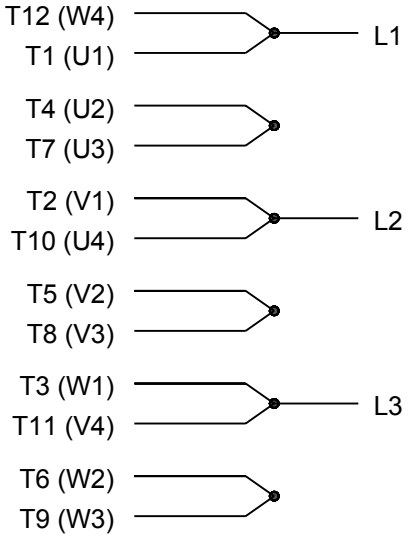

### HIGH VOLTAGE

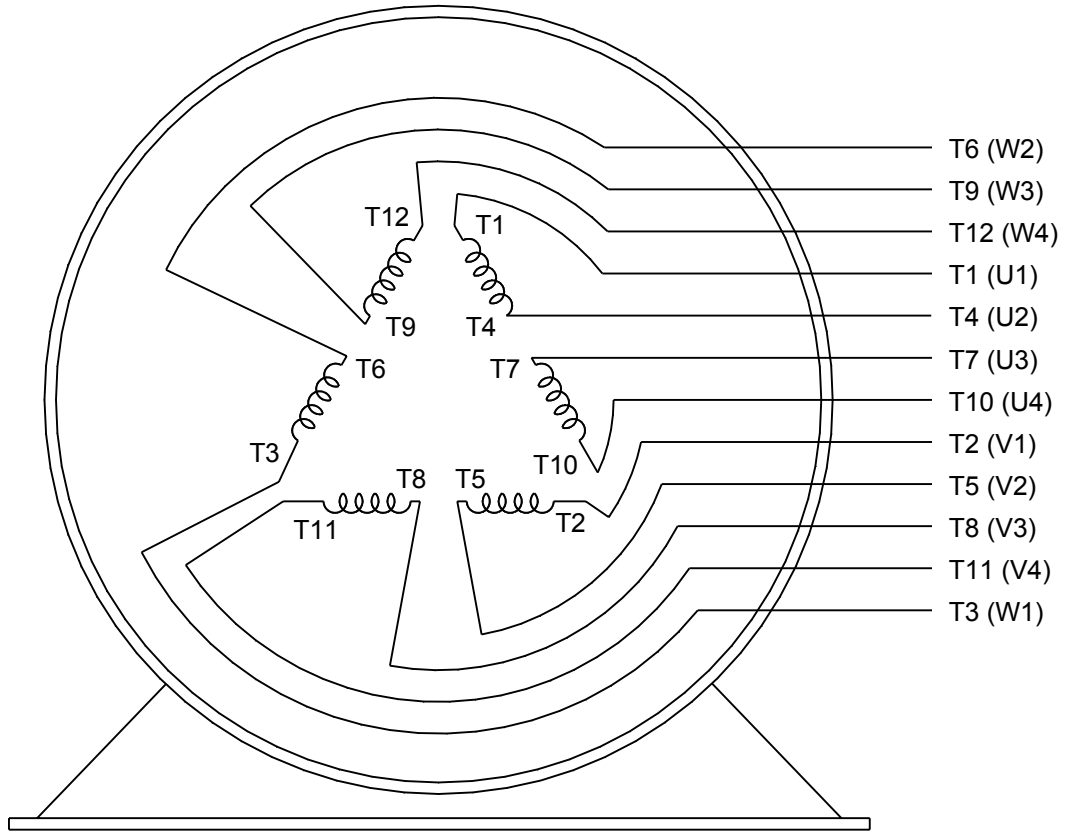

DRAWING REVISION <b>K</b>	REVISION BY <b>AJW</b>	DATE <b>07-17-2015</b>
ECO <b>ECO-0081632</b>	APPROVED BY <b>T. VUE</b>	DATE <b>07-17-2015</b>
ECO DESCRIPTION <b>REV'D IEC MARKINGS PER IEC 60034-8</b>		
<small>COPYRIGHT REGAL BELOIT AMERICA, INC. ALL RIGHTS RESERVED.                  PROPRIETARY AND CONFIDENTIAL INFORMATION - THIS DOCUMENT IS THE PROPERTY OF                  REGAL BELOIT AMERICA, INC. ("OWNER") AND CONTAINS OWNER'S PROPRIETARY                  INFORMATION. ANY PERSON, CORPORATION OR OTHER FIRM RECEIVING IT IS DEEMED,                  BY RECEIVING IT, TO AGREE THAT IT, AND/OR ANY PART OF IT, SHALL NOT BE DISCLOSED                  TO ANY PERSON, CORPORATION OR OTHER ENTITY, DUPLICATED, AND/OR USED, EXCEPT                  AS EXPRESSLY APPROVED IN WRITING IN ADVANCE BY OWNER. THIS DOCUMENT SHALL                  BE RETURNED TO OWNER UPON REQUEST. IT MAY BE SUBJECT TO CERTAIN                  RESTRICTIONS UNDER APPLICABLE EXPORT CONTROL LAWS AND REGULATIONS.</small>		

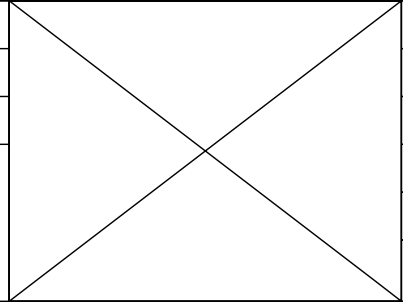

DRAWN BY <b>LZ</b>
DATE <b>01-12-1994</b>
APPROVED BY <b>GK</b>
DATE <b>01-14-1994</b>
REFERENCE
THIRD ANGLE PROJECTION

<b>Regal Beloit America, Inc.</b>	
<b>DESCRIPTION</b> <b>CONN DIAGRAM-EXTERNAL</b> <b>3Ø-2/1 DELTA-12 LEADS</b>	
MATERIAL	PROCESS/FINISH
SIZE <b>A</b>	DRAWING NUMBER <b>EE7308AA</b>
SHEET <b>1 OF 1</b>	



**P.O. BOX 8003  
WAUSAU, WI 54401-8003  
PH. 715-675-3311**

**CERTIFICATION DATA SHEET**

**CUSTOMER:**

**CUSTOMER PO#:**

**ORDER #:**

**MODEL #:** 326TTFCD6028 AA

**CONN. DIAGRAM:** EE7308AA

**CUSTOMER PART #:**

**OUTLINE:** SS312784-326TC

**MOUNTING:** F1/F2 CAPABLE

**WINDING #:** HE32004006 2

**TYPICAL MOTOR PERFORMANCE DATA**

HP	kW	SYNC. RPM	F.L. RPM	FRAME	ENCLOSURE	KVA CODE	DESIGN
50&40	37.0&30.0	1800	1780&1475	326TC	TEFC	G	B

PH	Hz	VOLTS	AMPS	START TYPE	DUTY	INSL	S.F.	AMB°C
3	60/50	230/460&190/380	117/58.5&115/57.5	Y START D RUN OR INV	CONTINUOUS	F2	1.15/1.15	40

FULL LOAD EFF:	94.5&94.1	3/4 LOAD EFF:	94.5	1/2 LOAD EFF:	94.1	GTD. EFF		ELEC. TYPE	
FULL LOAD PF:	85&85	3/4 LOAD PF:	82	1/2 LOAD PF:	73.8	94.1		SQ CAGE INV RATED	

F.L. TORQUE	LOCKED ROTOR AMPS	L.R. TORQUE	B.D. TORQUE	F.L. RISE°C
147.5 LB-FT	724 / 362	275 LB-FT 180 %	395 LB-FT 260 %	65

SOUND PRESSURE @ 3 FT.	SOUND POWER	ROTOR WK^2	MAX. WK^2	SAFE STALL TIME	STARTS / HOUR	APPROX. MOTOR WGT
65 dBA	75 dBA	12 LB-FT^2	- LB-FT^2	20 SEC.	2	775 LBS.

**\*\*\* SUPPLEMENTAL INFORMATION \*\*\***

DE BRACKET TYPE	ODE BRACKET TYPE	MOUNT TYPE	ORIENTATION	SEVERE DUTY	HAZARDOUS LOCATION	DRIP COVER	SCREENS	PAINT
C-FACE	STANDARD	RIGID	HORIZONTAL	FALSE	DIVISION 2 T2B	FALSE	NONE	BLUE - MARATHON

BEARINGS		GREASE	SHAFT TYPE	SPECIAL DE	SPECIAL ODE	SHAFT MATERIAL	FRAME MATERIAL
DE	ODE						
BALL	BALL	POLYREX EM	T	NONE	NONE	1045 HOT ROLLED (C-204)	CAST IRON
6312	6212						

THERMO-PROTECTORS				THERMISTORS	CONTROL	SPACE HEATERS
THERMOSTATS	PROTECTORS	WDG RTDs	BRG RTDs			
NONE	NOT	NONE	NONE	NONE	FALSE	NONE VOLTS

\*  
N  
O  
T  
E  
S  
\*

<b>INVERTER TORQUE:</b> VARIABLE 10:1
<b>INV. HP SPEED RANGE:</b> NONE
<b>ENCODER:</b> NONE NONE NONE NONE NONE PPR
<b>BRAKE:</b> NONE NONE NONE P/N NONE NONE NONE NONE FT-LB NONE V NONE Hz

**PREPARED BY:** Fareeda Dudekula  
**DATE:** 05/14/2018 01:06:01 AM  
FORM 3531 REV.3 02/07/99  
\*\* Subject to change without notice.

5 of 6

Data Sheet

Date: 5/3/2018  
 Customer: \_\_\_\_\_  
 Attention: \_\_\_\_\_  
 Submitted by: FAREEDA DUDEKULA



326TTFCD6028

Submittal

Data @ 460 V

Motor Load Data

Load	0%	25%	50%	75%	100%	115%	125%	LR
Current (Amps)	20.5	24.5	34.0	45.5	58.5	67.0	73.0	362
Torque (ft-lb)	0.00	36.5	73.5	110	148	170	185	265
RPM	1800	1795	1790	1788	1782	1,778	1775	0
Efficiency (%)		91.0	94.1	94.5	94.5	94.1	93.6	
P.F. (%)	4.5	52.0	73.8	82.0	85.0	85.8	85.8	32.0

Motor Speed Data

	LR	Pull-Up	BD	Rated	Idle
Speed (RPM)	0	900	1710	1782	1800
Current (Amps)	362	285	206	58.5	20.5
Torque (ft-lb)	265	225	383	148	0.00

Information Block

HP	50.0			
Sync. RPM	1800			
Frame	326182TTFCD6080			
Enclosure	TEFC			
Construction	TFC			
Voltage	230/460#190/380 V			
Frequency	60 Hz			
Design	B			
LR Code letter	G			
Service Factor	1.15			
Temp Rise @ FL	65 °C			
Duty	CONT			
Ambient	40 °C			
Elevation	1,000 feet			
Rotor/Shaft wk <sup>2</sup>	12.0 Lb-Ft <sup>2</sup>			
Ref Wdg	HE32004006 NONE			
Sound Pressure @ 1M	65 dBA			
VFD Rating	VARIABLE 10:1			
Outline Dwg	SS312784			
Conn. Diag	EE7308AA			
Additional Specifications:				
0				
0				
EQUIV CKT (OHMS / PHASE)				
R1	R2	X1	X2	Xm
0.0820	0.0490	0.3860	0.7030	13.0410

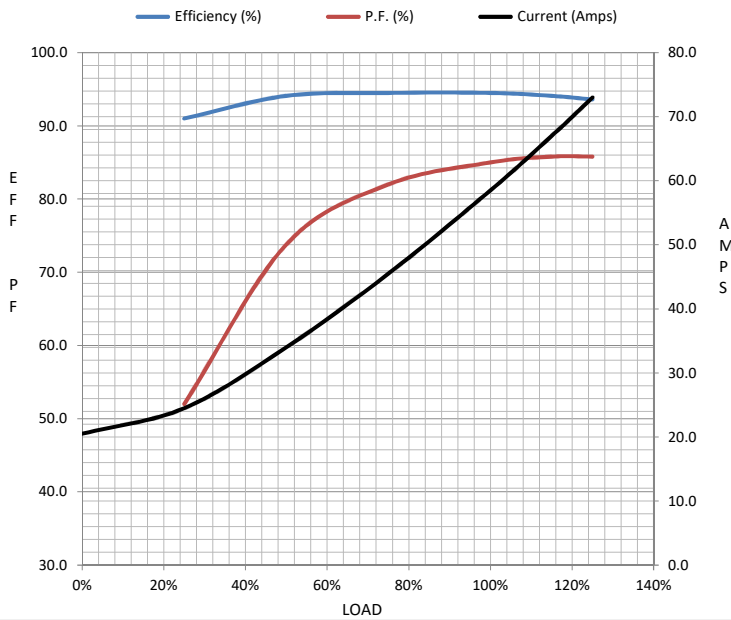

Speed - Torque Curve

